

**Compact,  
connected and  
convenient:  
Reliability  
and great  
performance for  
your business**



People. Passion. Performance.



# Experience the new CPI 75-120, CPM 75-120 & CPVSM 75-120 screw compressors

## Connectivity and optimization leads to performance

The new range offers you increased performance and the reliability of the Chicago Pneumatic brand. The advanced connectivity and the intuitive controller add intelligence, ease of use and the gathering of insights to your compressor. It will allow you to decrease operating costs and increase productivity based on your situation and needs.

Ready to discover our new compressors?

## Key differentiators

By optimizing each individual component we have ensured that we deliver you our most innovative compressor.

### 1 Next generation screw elements

- They deliver superior performance and efficiency.
- Improved rotor profile, reduced pressure losses.
- In-house designed and produced.

### 2 Infographic controller

- Intuitive full-color graphical display with touchscreen.
- Integrated connectivity to help optimize and save energy.
- In-house designed.



### 3 An integrated dryer (not for CPVSM & CPM)\*

- For enhanced air quality and with a deduced footprint, up to 1/3 of a stand-alone dryer.
- Condensate removal at the source, minimizing pipework corrosion.
- Single service visit, reducing maintenance cost.
- No extra installation cost.

### 4 Casted oil separator vessel

- Integrated minimum pressure valve (MPV) eliminates risk of leakage.
- Designed for optimal oil separation and low oil carry over

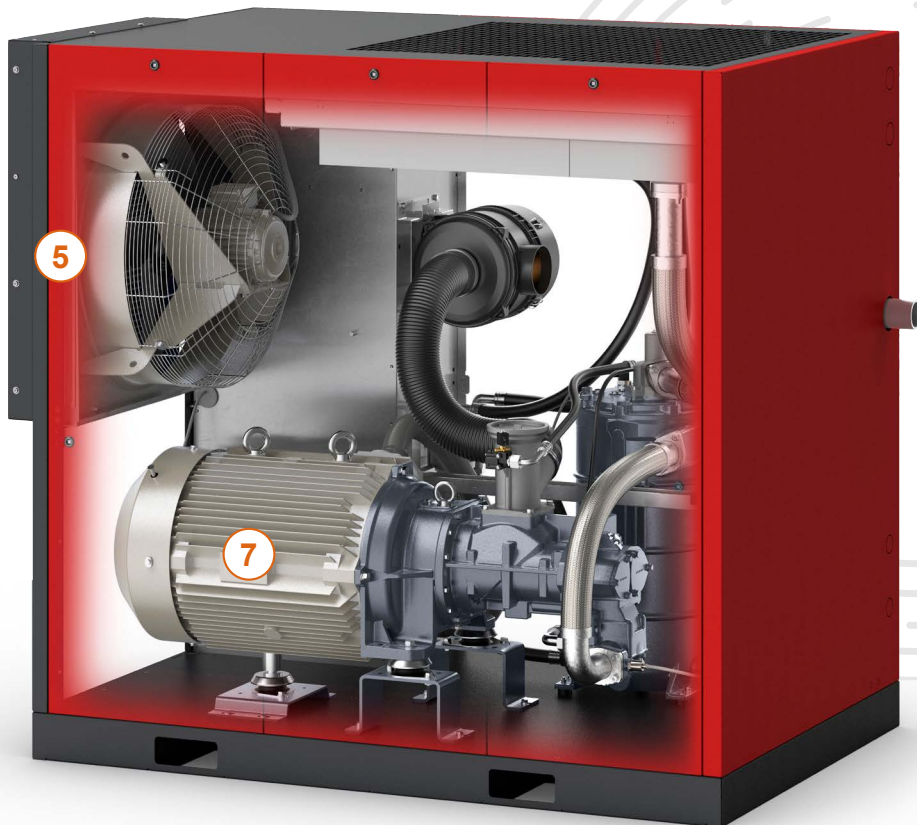

### 5 Quality filtration

- Protecting internal components and increasing lifetime.
- Heavy duty air/oil/oil separator filters with long lifetime for low total cost of ownership.

### 7 High efficiency motor

- IE4 Super Premium efficiency class.
- IP55 protection against dust ingress.

### 6 Separate coolers

- Separate oil and air cooler for high-quality cooling and long lifetime of the coolers.
- Gliding rails for easy and safe removal.
- Easy access for cleaning.
- Integrated water separation for coolers used on machines with integrated dryers.



# Main features



## New air end

- The compression element is in-house designed. Combined with an IE4 efficiency motor it leads to increased performance, lower compression temperature and high reliability.
- The Free Air Delivery is increased up to +4% and power consumption is reduced by up to -3%.
- The superior component design makes it fit for environments with ambient temperatures of up to 46°C.



## Integrated dryers for better air quality (not for CPM)

- Units with an integrated dryer have a water separator drain to remove condensate from the cooler.
- Removing condensate improves the air quality.



## High efficiency motor

- IE4 Super Premium efficiency class.
- IP55 protection against dust ingress.



## Easy installation and service

- Easily removable panels and quick access to all service parts guarantee effortless maintenance.
- Low maintenance costs.



## Infographic controller

- Intuitive and easy-to-operate.
- Insight into the performance of your compressed air system – remotely and at any given moment.
- Control by maintaining the pressure between programmable limits.
- Programmed shutdown warnings to protect the unit.
- Programmed service time interval meter, informing the customer when service is due.



# Full insight into your compressor system with the ES4000Touch controller

The ES4000S features an intuitive user interface with simple symbols for easy navigation. For advanced user experience we suggest the ES4000T which has a state-of-the-art 4.3" full-color touchscreen.

But the ES4000S & ES4000T both take ease of use a step further. Thanks to the connectivity features you can check your compressor's service status anywhere, at any time, in real time and that improves the reliability of your overall operations.

Service interventions can be planned at the right moment and it avoids production downtime by detecting potential problems before they become a liability.



\*for Fixed Speed compressors (standard on Variable Speed compressors)

## ICONS



## The ICONS plan: all your compressor information direct to any device you want

Urgent servicing or an immediate intervention? With an ICONS plan, alerts are delivered from your controller straight to your computer, tablet or smartphone. Reduce the risk of downtime and other costs with a swift reaction to alerts.

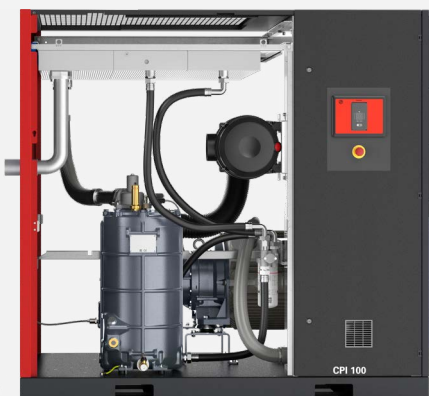

## A smart cooling system with more power

- Bigger air oil coolers make sure your compressor has a high cooling capacity, maximum cooling efficiency and increased reliability.
- The large fan improves the air flow and reduces operating temperature for enhanced reliability.

# Built-in options

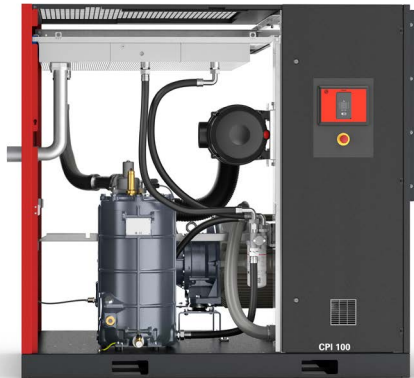

## Air Quality

### Integrated water separation drains

To ensure efficient condensate draining.

### Tropical thermostatic valve

For the use in humid and hot conditions.

### Freeze protection

Guarantees a certain oil temperature in the oil vessel to avoid condensation.

### Integrated refrigerant dryer

Removes water condensate from the compressed air, minimizing the risk of product spoilage in your application.

## Energy Saving

### Integrated energy recovery

Recovers up to 75% of the heat energy formed during the compression process, which can be used to heat up water for boilers, showers, etc.

### ECO2i – ECO4i – ECO6i

Integrated multiple compressor control for up to 6 compressors to reduce system pressure and energy consumption.

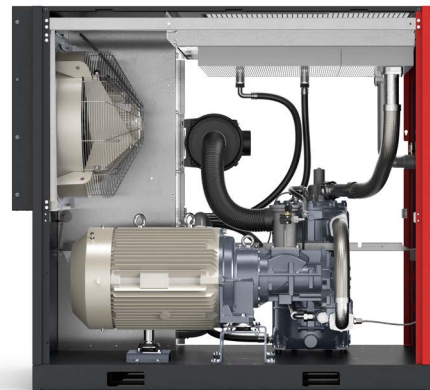

## A range of options

- WATER SEPARATION DRAIN - MECHANICAL (PACK ONLY)
- INTEGRATED ENERGY RECOVERY
- OIL - 8000H OIL SYNTHETIC
- WATER SEPARATION DRAIN - ELECTRONIC
- EXPANSION MODULE

- UPGRADE TO TOUCH
- PREFILTER KIT
- POWER DUCT FAN - AC\*
- OIL PREHEATER = FREEZE PROTECTION
- OIL - 4000H OIL FOOD GRADE

- ECO2i
- ECO4i
- ECO6i
- TROPICAL THERMOSTAT
- COMPRESSOR RUNNING-L/UL SIGNAL - REMOTE CONTROL

\* Not on 120Hp

# Performance data

## CPI 75-120 (50HZ)

Model	Max working bar(g)	Reference working bar(g)	Free air delivery @ reference conditions			Motor power		Noise level dB(A)	Cooling air volume m³/h	Weight		Compressed air output diameter
			m³/h	l/s	cfm	kW	Hp			STD kg	PLUS kg	
CPI75	7,5	7	626	174	368	55	75	71	10224	1308	1616	2 ½"
	8,5	8	598	166	352	55	75	71	10224	1308	1616	2 ½"
	10	9,5	536	149	316	55	75	70	10224	1308	1616	2 ½"
	13	12,5	474	132	279	55	75	70	10224	1308	1616	2 ½"
CPI100	7,5	7	808	224	475	75	100	73	10224	1417	1738	2 ½"
	8,5	8	779	216	458	75	100	72	10224	1417	1738	2 ½"
	10	9,5	720	200	424	75	100	73	10224	1417	1738	2 ½"
	13	12,5	622	173	366	75	100	73	10224	1417	1738	2 ½"
CPI120	7,5	7	1020	283	601	90	120	72	15336	1566	1892	2 ½"
	8,5	8	976	271	574	90	120	71	15336	1566	1892	2 ½"
	10	9,5	901	250	530	90	120	73	15336	1566	1892	2 ½"
	13	12,5	760	211	448	90	120	71	15336	1566	1892	2 ½"

## CPI 75-120 (60HZ)

Model	Max working bar(g)	Reference working bar(g)	Free air delivery @ reference conditions			Motor power		Noise level dB(A)	Cooling air volume m³/h	Weight		Compressed air output diameter
			m³/h	l/s	cfm	kW	Hp			STD kg	PLUS kg	
CPI75	6,9	7	636	177	375	55	75	71	10224	1308	1616	2 ½"
	8,6	8	581	161	342	55	75	71	10224	1308	1616	2 ½"
	10,3	9,5	553	154	325	55	75	73	10224	1308	1616	2 ½"
	12	12,5	505	140	297	55	75	70	10224	1308	1616	2 ½"
CPI100	6,9	7	815	226	480	75	100	73	10224	1417	1738	2 ½"
	8,6	8	777	216	457	75	100	73	10224	1417	1738	2 ½"
	10,3	9,5	704	195	414	75	100	73	10224	1417	1738	2 ½"
	12	12,5	634	176	373	75	100	73	10224	1417	1738	2 ½"
CPI120	6,9	7	1058	294	623	90	120	72	15336	1566	1892	2 ½"
	8,6	8	951	264	559	90	120	72	15336	1566	1892	2 ½"
	10,3	9,5	872	242	513	90	120	71	15336	1566	1892	2 ½"
	12	12,5	759	211	447	90	120	71	15336	1566	1892	2 ½"

## CPM 75-120 (50HZ)

Model	Max working bar(g)	Reference working bar(g)	Free air delivery @ reference conditions			Motor power		Noise level dB(A)	Cooling air volume m³/h	Weight		Compressed air output diameter
			m³/h	l/s	cfm	kW	Hp			STD kg	PLUS kg	
CPM75	7,5	7	617	171	363	55	75	71	10224	1308	1308	2 ½"
	8,5	8	580	161	342	55	75	71	10224	1308	1308	2 ½"
	10	9,5	520	144	306	55	75	70	10224	1308	1308	2 ½"
CPM100	7,5	7	794	221	468	75	100	73	10224	1417	1417	2 ½"
	8,5	8	769	213	452	75	100	72	10224	1417	1417	2 ½"
	10	9,5	709	197	417	75	100	73	10224	1417	1417	2 ½"
CPM120	7,5	7	970	270	571	90	120	71	15336	1566	1566	2 ½"
	8,5	8	923	256	543	90	120	71	15336	1566	1566	2 ½"
	10	9,5	852	237	501	90	120	71	15336	1566	1566	2 ½"

## CPM 75-120 (60HZ)

Model	Max working bar(g)	Reference working bar(g)	Free air delivery @ reference conditions			Motor power		Noise level dB(A)	Cooling air volume m³/h	Weight		Compressed air output diameter
			m³/h	l/s	cfm	kW	Hp			STD kg	PLUS kg	
CPM75	7,4	6,9	622	173	366	55	75	71	10224	1308	1308	2 ½"
	9,1	8,6	564	157	332	55	75	70	10224	1308	1308	2 ½"
	10,8	10,3	523	145	308	55	75	70	10224	1308	1308	2 ½"
CPM100	7,4	6,9	804	223	473	75	100	73	10224	1417	1417	2 ½"
	9,1	8,6	754	209	444	75	100	73	10224	1417	1417	2 ½"
	10,8	10,3	692	192	407	75	100	73	10224	1417	1417	2 ½"
CPM120	7,4	6,9	973	270	573	90	120	71	15336	1566	1566	2 ½"
	9,1	8,6	899	250	529	90	120	72	15336	1566	1566	2 ½"
	10,8	10,3	806	224	474	90	120	71	15336	1566	1566	2 ½"

## CPVSM 75-120

CP	Motor power		Working pressure bar(g)	Min. Free air delivery (100psi)			Max. Free air delivery					Noise level dB(A)	Cooling air volume m³/h	Weight STD kg	Compressed air output diameter	
				7	7	7	7	7	7	9,5	9,5					9,5
	kW	Hp	m³/h	l/s	cfm	m³/h	l/s	cfm	m³/h	l/s	cfm	m³/h	l/s	cfm		
CPVSM75	55	75	4-10bar	101	28	59	645	179	380	579	161	341	73*	10224	966	2 ½"
CPVSM100	75	100	4-10bar	97	27	57	772	214	454	714	198	420	74*	10224	995	2 ½"
CPVSM120	75	100	4-10bar	154	43	91	1041	289	613	914	254	538	72	10224	1148	2 ½"

\*measured with optional silencing baffle

## DIMENSIONS (mm)

	Length	Width	Height
Without Dryer	2135	1221	1804
With Dryer *not for CPVSM & CPM	2979	1221	1804



At Chicago Pneumatic we have a passion for performance and long-lasting partnerships. Since 1901, we have been committed to reliability based on technology and trust.

A large, stylized graphic of a fingerprint, composed of numerous red lines of varying lengths and curves, creating a sense of motion and precision. It is centered in the upper half of the page.

**People. Passion. Performance.**

For more information, please contact your CP partner:

Use only authorized parts. Any damage or malfunction caused by the use of unauthorized parts is not covered by Warranty or Product Liability.

[www.cp.com](http://www.cp.com)